

Name _____

CS 383
Exam 1
March 3, 2017

There are 6 numbered questions. The 6 parts of Question 1 are worth 4 points each. Questions 2 through 6 are worth 15 points each. You get one point for free.

1. Which languages are regular? You don't need to prove your answer. Write an "R" in the blank next to the description of each language you think is regular. Write "N" for any language you think is not regular. In each case the alphabet is $\Sigma=\{0,1\}$
 - a. _____ Strings where the number of 0's and the number of 1's are either both even or both odd.
 - b. _____ Strings of odd length with 1 in the center, such as 0001000 or 1101100
 - c. _____ Strings of the form $\alpha\beta$ where $|\alpha| = |\beta|$ such as 000111
 - d. _____ Strings that start and end on the same digit, such as 1010101 and 0001110
 - e. _____ Strings that have the same numbers of 0's and 1's
 - f. _____ Strings whose digits sum to no more than 1000.

2. Here is an ϵ -NFA, with start state A. Convert this NFA to a DFA and describe in English the strings it accepts.

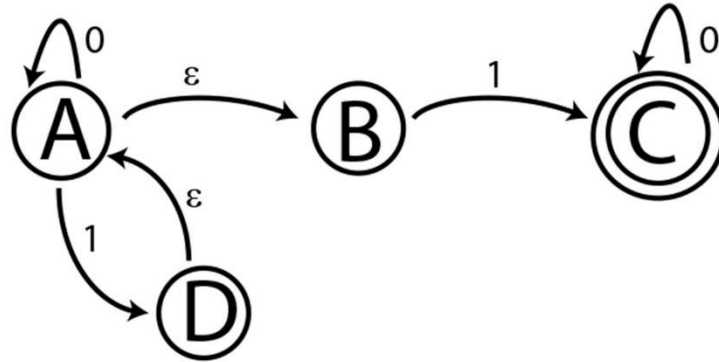

3. Find an ε -NFA that accepts the language described by the regular expression $1(00+11)^*01$

4. Consider the following DFA. We had an algorithm for converting a DFA to a regular expression. This involved making a table of regular expressions r_{ij}^k .

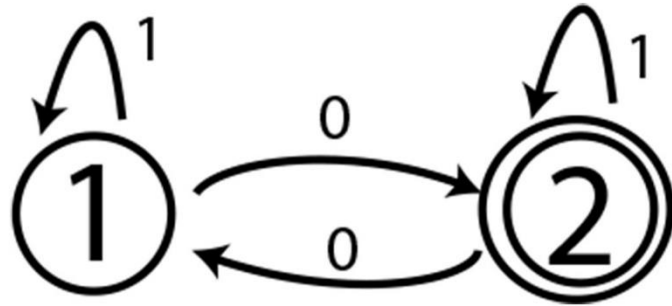

Here is the first column of a table of the r_{ij}^k expressions; find the 4 entries of the second column.

| | k=0 | k=1 |
|------------|--------------|-----|
| r_{11}^k | $\epsilon+1$ | |
| r_{12}^k | 0 | |
| r_{21}^k | 0 | |
| r_{22}^k | $\epsilon+1$ | |

5. Here's a definition of a regular expression over the alphabet Σ :

- a. ε and \emptyset are regular expressions
- b. Any string in Σ^* is a regular expression
- c. If E and F are regular expressions then so are $E+F$, EF , and E^* .

Use Structural Induction to show that any regular expression that does not use the $*$ operator describes a finite language.

6. Give a careful proof of the fact that the language $\{0^n 1^m \mid n > m\}$ is not regular.

This page is extra space. If you want me to grade anything here indicate that clearly.

Please write and sign the Honor Pledge when you have finished the exam.